

POWRWHEEL LIMITED MANUFACTURERS OF THE UK's No: 1 REMOTE CONTROL CARAVAN & TRAILER MOVING SYSTEMS

INSTRUCTIONS for the Installation, Operation, Use, Safety & Maintenance of the Powrtouch moving System



1) If you have purchased direct from Powrwheel Limited your proof of purchase will state your unique Powrtouch Serial Numbers. Please transfer them to this document for your convenience.

2) If you have purchased from another supplier then they should register your information with Powrwheel Limited (Always ask your supplier to ensure that this has been done).

PLEASE NOTE THAT YOUR POWRTOUCH GUARANTEE IS NOT
AUTOMATICALLY TRANSFERABLE TO A NEW OWNER SEE SECTION 4 –
PARAGRAPH 4.1 OF THIS DOCUMENT.

CUSTOMER NAME:.....

POWRTOUCH SERIAL No: PWRT.....

ELECTRONICS SERIAL No:

BEFORE CONTACTING POWRWHEEL LIMITED WITH A FAULT OR GUARANTEE
ENQUIRY PLEASE PAY SPECIAL ATTENTION TO SECTION 4 OF THIS
DOCUMENT.

Powrwheel Limited, Registered in England, Registration Number 4038096
6, Priory Industrial Estate, Airspeed Road, Christchurch, Dorset, United Kingdom, BH23 4HD
Opening Hours: 0830 to 1730 Monday to Friday ONLY

TELEPHONE: - Tel: +44(0)1425 283293, then dial 1 for Sales or 2 for Technical Help
FAX: +44(0)1425 283292

Website: - www.powrwheel.com

email: - info@powrwheel.com

ISSUE 8.0

DATED: 9th June 2011

CONTENTS

SECTION 1 – USING YOUR POWRTOUCH

- 1.1 Safety checks required prior to Powrtouch usage
- 1.1a Safety and Technical Awareness
- 1.2 Powrtouch Operation
- 1.2a Isolation Switch
- 1.2b Emergency Stop
- 1.3 Switching on the Powrtouch
- 1.4 Initialisation of System
- 1.5 Switching on the Handset
- 1.5a Battery Replacement
- 1.5b Umbilical Cable
- 1.6 Electronic Engagement of the rollers on to the tyres using the Powractorator System – (Optional extra)
- 1.6a Manual Engagement of the rollers on to the tyres using the wrench (supplied)
- 1.7 Moving the Caravan (Handset Operation)
- 1.8 Decreasing Speed
- 1.9 Increasing Speed
- 1.10 Use of Soft Start
- 1.11 Electronic Retraction of the rollers off the tyres using the Powractorator System – (Optional extra) with emergency removal procedures in the event of a motor/system malfunction.
- 1.11a Manual Retraction of the rollers off the tyres using the wrench (supplied)
- 1.12 Switching off the Handset
- 1.13 Mapping Instructions

SECTION 2 – DIY FITTING INSTRUCTIONS

- 2.1 Receiving your Powrtouch
- 2.2 Tooling & Equipment Required
- 2.3 Installing your Powrtouch
- 2.4 Checking Chassis Depth
- 2.5 Special Mounting Plates
- 2.6 Mechanical Assembly
- 2.7 Powrbar Installation
- 2.8 Electrical Assembly
- 2.9 Connecting to the Caravan Battery

SECTION 3 – LOOKING AFTER YOUR POWRTOUCH

- 3.1 Cleaning your Powrtouch
- 3.2 Cleaning the Drive Rollers
- 3.3 Greasing your Powrtouch

SECTION 4 – GUARANTEE & FAULT FINDING

- 4.1 Powrtouch Guarantee
- 4.2 Reporting a Fault with your Powrtouch
- 4.3 Electronics Control Box - LED Status
- 4.4 Fault Finding on your Powrtouch
- 4.5 Checking the Charge State of your 12 volt Battery

ADDITIONAL INFORMATION TO NOTE

Note 1: To the best of our knowledge these instructions were accurate at the date of publication.

Note 2: Wherever the Powrtouch is fitted this should be done in accordance with the local standards applicable to the installation of a remote controlled caravan moving system.

SECTION 1 – USING YOUR POWRTOUCH

1.1. SAFETY CHECKS REQUIRED PRIOR TO USING YOUR POWRTOUCH PLEASE READ CAREFULLY:

BEFORE MOVING THE CARAVAN WITH THE POWRTOUCH FOR SAFETY REASONS IT SHOULD ALWAYS BE TESTED, TO DO THIS TURN ON THE POWRTOUCH AT THE ISOLATION SWITCH – DO NOT PUT THE ROLLERS ON TO THE TYRES. WITH THE ROLLERS OFF THE TYRES CHECK ALL THE HANDSET FUNCTIONS ARE DRIVING THE ROLLERS CORRECTLY. ONCE THIS TEST HAS BEEN SATISFACTORILY COMPLETED ONLY THEN SHOULD YOU PUT THE ROLLERS ON THE TYRES AND COMMENCE MOVING THE CARAVAN.

IF IN DOUBT CONTACT POWRWHEEL LIMITED

1.1a. SAFETY & TECHNICAL AWARENESS

Please read the following instructions and technical information carefully and become familiar with the various components and controls prior to assembly and/or operation. Safety must always be the first consideration in fitting or operation. Failure to comply with these instructions could invalidate your Powrtouch guarantee. If you are in any doubt about the assembly or operation of the product consult a qualified Powrtouch Engineer, for which contact details are shown on the front cover

- The Powrtouch Caravan Mover (except handset) is a 12volt D.C. powered device and it should not under any circumstances be powered by any other power source than a 12 volt DC leisure battery. n.b. Using the Powrtouch with the caravan connected to the 240volt mains could cause damage to the caravan internal charging system.
- The 12 volt leisure battery MUST be fully charged and in good condition to enable the Powrtouch to operate to its full performance specification – to check your battery see Section 4 of this instruction manual.
- The handset must only be powered by a 9 volt DC battery (PP3 or equivalent). It can also be used with the umbilical cord connected to the Powrtouch electronics control box.
- The wiring and cabling supplied by Powrtouch for its installation are to the correct voltage and current rating, under no circumstance should any other wiring or cabling be used unless supplied by Powrtouch or written approval is given for their use. All power cables should be kept as short as possible and motor cables if cut (not recommended) should be of equal length, no cable joining system should be used to lengthen them.
- When the Powrtouch is switched on and/or in use there will be 12 volts at the two battery terminals on the electronics control box (ECB). Under no circumstance should any metal object be allowed to touch these terminals.
- The Powrtouch is not a caravan jacking point and should never be used as such.
- The Powrtouch is not a brake or braking system and should never be used as such. When stopped always apply the caravan handbrake.
- Be aware that the Powrtouch adds weight to the caravan and the corresponding weight of your mover must be considered when calculating your payload. If in

doubt the MTPLM of the caravan should be checked on a calibrated weighbridge.

- Never allow children or persons unfamiliar with the use of the Powrtouch to operate the unit.

1.2. POWRTOUCH OPERATION:

Carry out the Powrtouch pre-movement safety checks as Section 1 Paragraph 1.11; also ensure that the caravan is safe to move and that there are no obstructions to prevent the engagement of the drive rollers to the caravan tyres.

1.2.a PLEASE NOTE: ISOLATION SWITCH

When the Powrtouch is not in use it **MUST** always be turned off at the Isolation Switch and the key removed. If left switched on it will stay live for 20 minutes (approx.) before the electronics control box will go in to a hibernation mode. The electronics control box can only be reinitialised by turning it off, to do this turn the isolation switch key to the off position and remove the key from the switch for a minimum of 20 seconds. Then reinsert the isolation switch key; switch on the Powrtouch and then turn on the handset (see paragraph 1.5 below).

ALWAYS SWITCH IT OFF AND REMOVE THE KEY

1.2.b PLEASE NOTE: THE EMERGENCY SWITCH OFF.

In the event of a malfunction or emergency the handset should be switched OFF by pressing either of the D or F buttons, this sends a signal to the control board, which instantly drops the board voltage to 5V. The 5V will not run the motors and hence makes the control board unusable. Then turn off the Powrtouch at the isolation switch and remove the key, do not switch the Powrtouch back on before consulting a qualified Powrtouch Engineer.

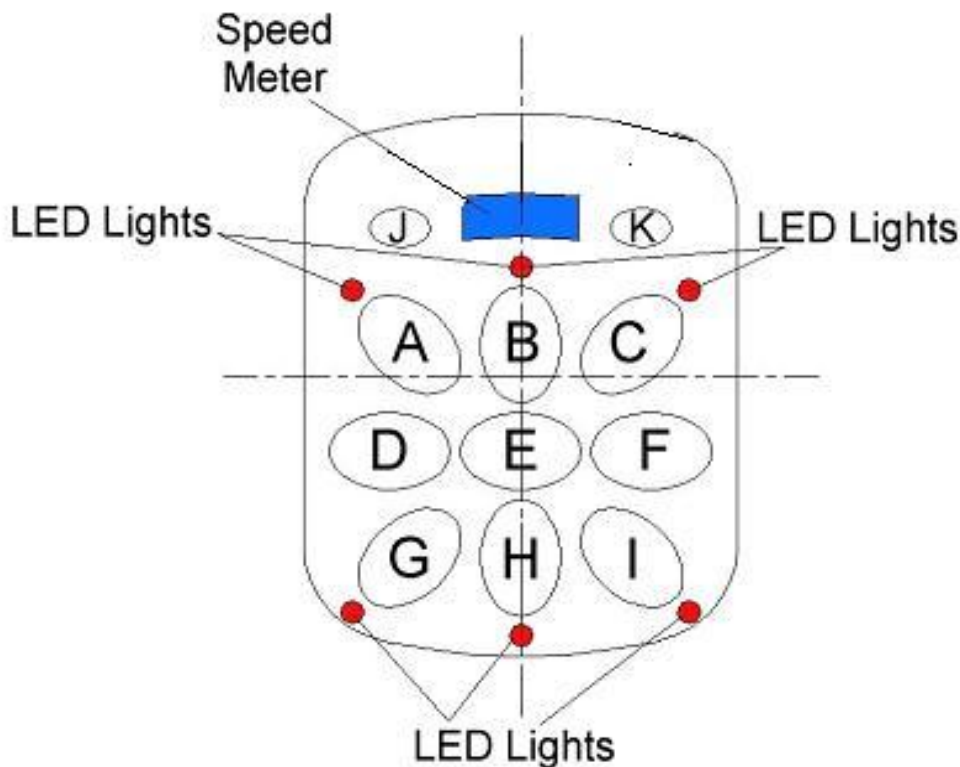

1.3. Switching on the Powrtouch

The Powrtouch mover is switched on by inserting the key into the isolation switch and then turning the key clockwise, the isolation switch is usually situated in the sealed area of the caravan battery box.

1.4. Initialisation of System

When the control board is switched on the unit first initializes, and then looks for the welcome/coding signal from the handset. The green light should illuminate on the control board situated in the caravan. (See Section 4 Paragraph 4.3)

1.5. Switching on the Handset

You switch on the handset by pressing and quickly releasing both D and F buttons at the same time. If the buttons are held down for too long the handset start up and will immediately turn off again. The LED array will illuminate and run through a sequencing process (system welcome/coding functions); once it is ready to operate then one green LED on the extreme right of the speed meter will remain on. If the six small RED LED Lights flash twice when the handset is switched on then this is an indication that the battery voltage of the handset is low and the battery should be changed as soon as possible.

1.5a Handset Battery Replacement

To replace the handset battery first remove the small crosshead screw on the back of the handset, when unscrewed and taken out then the battery box cover can be removed providing access to the battery, then the battery can then be removed from its connections and a new battery can be installed and the cover replaced. The battery required is a 9 Volt D.C. PP3 (mn1604) or equivalent. Note: The use of rechargeable batteries is not recommended.

1.5b Umbilical Cable

If a spare or new battery is not available then the system can be used with the umbilical cable that will provide the necessary power to the handset. To connect the cable firstly remove the blanking plug (small plastic cover) on the top of the handset to reveal a female jack plug socket, one end of the cable should be connected (plugged in) to this socket. The second female jack plug socket is situated under the hinged cover on the Electronics box, to locate the correct socket see diagram in Para 2.8 Electrical Assembly. Once these connections are made switch the Powrtouch on at the isolation key and the system will work normally and move in accordance with the movement direction buttons.

1.6. Electronic Engagement of the rollers on to the tyres using the Powractor System – (Optional extra)

With the Powrtouch isolation switched in the on position the rollers can be electronically engaged on to the wheels of the caravan, first press and hold Button E then press button B and release BOTH buttons at same time. Prior to the actuators operating the LED display (Speed Meter) on the handset will count down from four to one, once the countdown is complete the actuators will start to operate and the RED LED above button B will flash. Always check that **BOTH** rollers are fully engaged on to the tyres of the caravan before removing the handbrake.

If the actuators have been started by accident and need to be stopped immediately then press buttons D or F, see Emergency Switch Off paragraph 1.2.

1.6a Manual Engagement of the rollers on to the tyres using the wrench (supplied)

If the rollers are to be manually engaged then this can be done with the wrench and 19mm socket by turning the over locking cam system through 200 degrees. On the Powrtouch Heavy Duty, Standard Twin and All Wheel Drive Models the start position for the wrench should be as low as possible to the ground with the handle pointing away from the rollers, on the Powrcompact Model ONLY the handle should be positioned as above but pointing towards the roller. Always take great care with this operation as the over locking cam system together with its return spring require some force to move the rollers into position against the tyres. This manual operation needs only to be done from

one side of the caravan if the Powrbar (optional extra) is fitted. Your Powrtouch fitter or supplier will have shown how to carry out this operation safely.

If in doubt consult a qualified Powrtouch Engineer.

Note the following: Always check that **BOTH** rollers are fully engaged on to the tyres of the caravan before removing the handbrake. If a Powrbar is fitted and roller engagement has been made from one side of the caravan then at the earliest opportunity (i.e. immediately it is safe to access the other side of the caravan), then check the opposite side roller is also fully engaged to the tyre

Once the Rollers are engaged before attempting to move the caravan/trailer ensure handbrake is off.

1.7. Moving the Caravan (Handset Operation)

Ensure that the Powrtouch isolation switch is in the on position, then the caravan can be moved as required by pressing buttons A, B, C, G, H or I the caravan will move in the direction of the arrows printed on these buttons. Pressing opposite button A and I or C and G will make **single axle** caravans (**only**) rotate on their axis. The Electronics Control System also has a continuous movement capability in that if button B is being pressed then buttons A or C can be used, alternatively if button H is pressed then buttons G or I can be used. Using this sequence of button pressing will allow the Powrtouch to redirect the caravan without stopping the forward or backward motion.

Please note that the speed settings will always default to MAXIMUM – Speed changes can only be made when the caravan is stationary

1.8. Decreasing speed.

When the handset is first switched on (and the system welcome/coding functions completed) the speed meter will always show an illuminated green led to the extreme right hand side of the meter and this will denote maximum speed (100%). The speed can be decreased in stages of 25% so if button J is pressed once the green led will move once to the left and the speed will be set at 75% of maximum. Button J can be pressed up to twice more reducing the speed to 50% and then to the slowest setting of 25% when the illuminated green light will now be in the extreme left hand side of the meter. **Note:** As the speed decreases the torque decreases in the same ratio i.e. 50% speed is 50% torque. This function of using a slow speed with lower torque setting is designed to maintain the caravan/trailer's manoeuvrability in very restricted and/or confined spaces. Please note: - Speed changes can only be when the caravan is stationary.

1.9. Increasing speed.

If the Powrtouch is not at its maximum speed then the speed can be increase in 25% increments by pressing button K. When changing the speed of the Powrtouch the illuminated green led will move (a maximum four stages) from the left to the right of the meter; when the led is positioned at the extreme right of the meter it will show the Powrtouch has returned to the maximum speed setting. The speed can only be changed when the caravan is not moving. (See Section 1 Paragraphs 1.7 & 1.8)

1.10. Use of Soft Start

By utilising its very effective Electronic Soft Start System the Powrtouch can easily move the caravan a distance of 10mm or even less. This small movement can be achieved by pressing and quickly releasing a direction button (stabbing the button), this facility makes attaching the caravan to the tow ball of the car a very simple operation. Reducing the speed will also give greater control of the caravan when using the soft start in this way. It is recommended that a good practice session should be carried out on level ground and in an open space before any difficult manoeuvres are undertaken.

**ALWAYS ENSURE THE HANDBRAKE IS ON BEFORE
DISENGAGING THE ROLLERS FROM THE TYRES**

1.11. Electronic Retraction of the rollers off the tyres using the Powractor System – (Optional extra)

Ensure that the handbrake is ON and then to actuate the rollers off the wheels of the caravan, first press and hold Button E first then press button H and then release BOTH buttons at same time. Prior to the actuators operating the LED display (Speed Meter) on the handset will count down from four to one, once the countdown is complete the actuators will start to operate and the RED LED below button H will flash.

If the actuators have been started by accident and need to be stopped immediately then press buttons D or F, see Emergency Switch Off (See Section 1 Paragraph 1.2).

Always check that the rollers are off the tyres of the caravan before towing

N.B. Should the rollers not retract from the tyres due to a motor/system failure then they can be removed manually. Depending upon the motor system fitted one of the following methods to retract the rollers can be used.

Motor System 1: This can be done by locating the rubber top hat on the rear of the small Powractor Motor and then remove this cover. Beneath this cover is a 9mm nut and by winding this nut anti-clockwise the roller will retract from the tyre. As the system is fitted with a reduction gearbox then if doing manually a large number of turns will be required to retract the rollers, therefore this is best done with a battery operated drill or screwdriver.

Motor System 2: Using the ‘tool for hand removal’ provided with the Powrtouch, insert this in the hole on the rear of the motor, this provides you with a 10mm nut that can then be removed as system 1.

1.11a. Manual Retraction of the rollers off the tyres using the wrench (supplied)

Ensure the handbrake is on prior to removing the rollers away from the tyres. If the rollers were manually engaged then they can be removed with the wrench by turning the cam system 200 degrees. The correct retraction start position for the wrench will be the opposite of the engagement positions as shown in Section 1 Paragraph 1.6a. Always take great care with this operation as the return spring will remove the rollers with some force that can snatch the wrench from your hand and damage the system. Your Powrtouch fitter or supplier will have shown how to carry out this operation safely.

If in doubt consult a qualified Powrtouch Engineer.

1.12. Switching off the Handset

The handset does not need to be turned off manually except in the case of an emergency (See Paragraph 1.2.2 above), if the handset is left unused for 30 seconds approximately it will automatically turn itself off. However; once you have finished using the Powrtouch caravan mover, ensure the unit is switched OFF with the isolation switch and the key removed.

1.13. Mapping (Tuning/Coding) Instructions – Given for Information ONLY

All electronics systems are supplied with the handset mapped (tuned/coded) to the electronics box, should you require to map or remap the system the sequence is as follows: Using the plastic needle provided (attached under the hinged lid of the electronics control box) press the remap button through the small hole in the lid of the box, this enables the control board to search for a signal. Then switch on the handset, and it will transmit a welcome mapping signal to the control board and the system will automatically code.

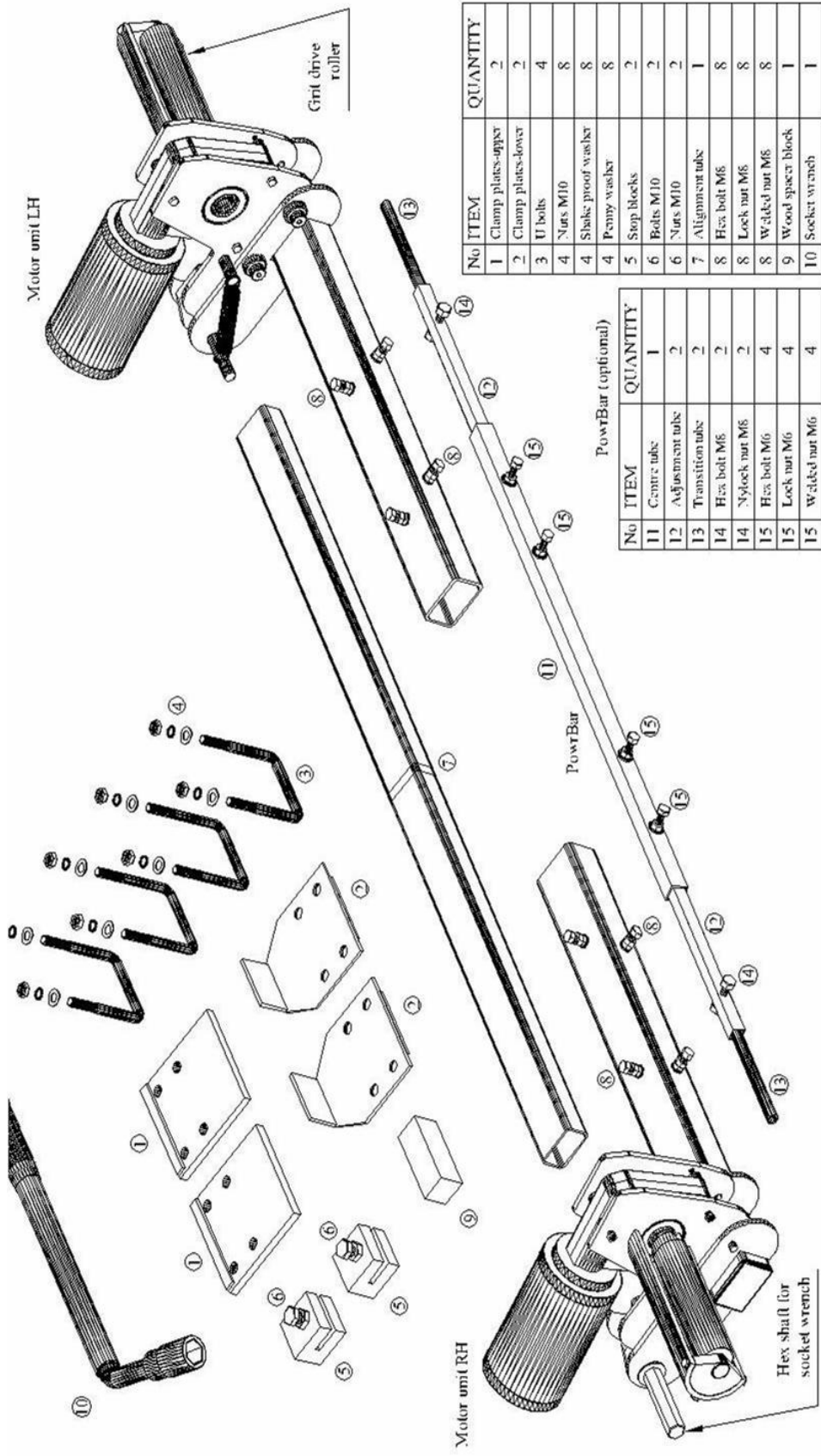

No	ITEM	QUANTITY
1	Clamp plates-upper	2
2	Clamp plates-lower	2
3	U bolts	4
4	Nuts M10	8
4	Shake proof washer	8
4	Penny washer	8
5	Stop blocks	2
6	Bolts M10	2
6	Nuts M10	2
7	Alignment tube	1
8	Hex bolt M6	8
8	Lock nut M6	8
8	Wadded nut M6	8
9	Wood spacer block	1
10	Socket wrench	1

PowrBar (optional)		
No	ITEM	QUANTITY
11	Centre tube	1
12	Adjustment tube	2
13	Transition tube	2
14	Hex bolt M6	2
14	Nylock nut M6	2
15	Hex bolt M6	4
15	Lock nut M6	4
15	Wadded nut M6	4

Fig 2. Drawing showing mechanical parts

SECTION 2 – DIY INSTRUCTIONS

2.1. Receiving your Powrtouch

When unpacking the box there is a checklist of the components of the mover. Please check that all parts have been received before commencing the installation work (See FIG 2 above). If in doubt please contact a Qualified Powrtouch Engineer. Contact details are on the front page of this document.

2.2. Tooling and Equipment required

To install the Powrtouch the following tooling and equipment will be required (not supplied):

- 8mm Socket & Ring Spanner
- 10mm Socket & Ring Spanner
- 13mm Socket & Ring Spanner
- 17mm Socket & Ring Spanner
- Power Drill with 3mm & 10 mm drills suitable for wood
- 25mm Hole saw for Plastic (for fitting isolation switch)
- Various Screwdrivers
- Multi Purpose Silicon Sealant
- Lighting as necessary
- Trolley jack or axle stands (for raising unit into position)
- Support blocks, wheel chocks for safety (to ensure the caravan cannot move during the fitting operation)
- 8mm Allen Key – Twin axle and Large Roller Units ONLY
- Torque Wrench
- Safety Goggles

2.3. Installing the Powrtouch

N.B. – VERY IMPORTANT

BEFORE COMMENCING, PLEASE ENSURE THAT THE CARAVAN IS DISCONNECTED FROM ITS 12 VOLT D.C. LEISURE BATTERY SUPPLY AND ANY OTHER ELECTRICAL SUPPLIES (INCLUDING 240 VOLT MAINS) ARE REMOVED.

All electronic and electrical controls of the system are carried out by the Electronic Control Box (ECB) and isolation switch, please note the ECB has in built safety thermal fuse (set at 90 deg C) should this fuse operate it will automatically reset when the system cools to an acceptable temperature.

The Isolation switch must be accessible at all times when parking and moving the caravan/trailer, please be aware of this when selecting the location for the switch (See paragraph 2.9 below).

Please check that the tyres are of the same size and design (preferable from the same manufacturer) and not over worn (fitting to new or nearly new tyres is the best option). It should be noted that as the caravan tyres wear the gaps will open which could cause the Powrtouch rollers to slip when driving the tyres should this occur the Powrtouch will require readjustment. Also ensure the tyre pressures are correct to the manufacturer's recommendation prior to commencing the fitting of a Powrtouch. Also check that the chassis is in good condition without any damage and free from rust or corrosion etc.

Ensure that the handbrake is in the ON position before the caravan is raised using the front steadies and Jockey Post/Wheel, the back steadies are then lowered to make sure the caravan is fully stabilised and no forward or backward movement can occur .

All work should be carried out to ensure personal safety.

2.4. Checking chassis depth:

All models with the exception of the Powrcompact are designed to fit on standard chassis depths of 200mm approximately. Some chassis are smaller at 150mm and will require a spacer to be fitted if a Powrcompact mover is not being used. This spacer kit will be supplied free of charge if requested at the time of ordering the Powrtouch. The fitting of the spacer kit is the same as the standard clamp kit described below but will be supplied with longer U bolts.

2.5. Special mounting plates:

On some recently manufactured caravans (in particular Hymer) special mounting plates are required. These plates can be supplied (for a small additional cost) and are fitted by nuts and bolts using pre-drilled holes in the chassis. Once these plates are fitted then the mechanical assembly of the unit will proceed as detailed below.

2.6. Mechanical Assembly:

For safety reasons it is recommended that the fitting of the Powrtouch should be undertaken on a flat hard standing. Before raising the caravan ensure the handbrake is on and then it can be raised as required (using trolley jack and/or axle stands) and secured in position using the caravan steadying legs with supporting blocks and wheel wedges as necessary; it is then helpful to lay down a ground sheet. Remove all items from the packaging onto the protective sheet. Ensure both rollers are in the DISENGAGED position, as the unit will not fit correctly otherwise. Loosely assemble the left hand motor unit, right hand motor unit and alignment tube as shown in fig. 5, and place under the caravan/trailer.

Wherever possible all Single Axle Powrtouch models should be fitted in front of the caravan/trailer road wheels, if this not possible then it is acceptable to fit behind these wheels. We recommend that the Standard Twin Axle Powrtouch should if possible be fitted behind the wheels of the rear axle, if fitting in this position is not possible due to obstructions, heater pipes, grey water exits etc. then it is permissible to fit in front of the wheels of the forward axle. However it is possible in most instances to move/reposition these obstructions but this is not the responsibility of Powrwheel Limited and you will have been informed of this in our formal Confirmation of Order Letter. If fitting a Standard Twin Axle Powrtouch behind the wheels or All Wheel Drive Powrtouch then it will be necessary to remove Mud Flaps and ALKO jacking points, this will have been agreed with you at point of sale and included in our formal Confirmation of Order Letter. If there is an under slung spare wheel carrier then this will also need to be re-sited, this can be done with our ALKO spare wheel moving kit. Please note it is not possible to refit a BPW spare wheel carrier and an AKLO system will be required (not supplied by Powrwheel Ltd.). Once the ALKO jacking points have been removed then an alternative jacking method should be sought – see Caravan Club Handbook – Technical Section – Jacking/changing a wheel.

Using appropriate support blocks raise the loosely assembled unit into an approximate position, fit the clamps and U-Bolts (see figure 3) to the chassis (do not tighten at this point). Adjust to the correct place using the wooden spacer provided between the tyre and the drive roller (on each side of the trailer).

The correct spacings are as follows:

Powrcompact (Small Rollers - 45mm diameter approx) at 20mm

Single Axle Heavy Duty (Small Rollers - 45mm diameter approx) at 20mm

Twin Axle & All Wheel Drive (Large Rollers - 65mm diameter approx) at 15mm

Also adjust the position of the drive rollers in relation to the tyres by sliding the motor units on the alignment tube until the maximum amount of roller is in contact with the tyre tread without any part of the unit fouling the tyre or chassis. It is advisable to leave a minimum 10mm gap between the Powrtouch unit and the inside wall of the tyre this is to allow for the expansion of the tyre when the rollers are engaged. If a Powractor is fitted they should be connected to a battery and run fully in and out to ensure they are in the correct position (fully retracted) prior to the final assembly. The assembly should then be fully tightened securely in place with a torque wrench set at 35 ft lbs. Please note the wood spacer blocks should be a sliding fit between the tyre and the coarse drive roller.

Check both the above alignments at least once during the process and on completion.

Once the motor assemblies are completed the stop blocks should now be fitted in a position behind the Powrtouch to ensure that the motor assemblies do not slide along the chassis away from the tyres when the drive rollers are engaged to the tyres (see fig. 3). Once correctly positioned they can be tightened using the locking bolt and nut with a torque wrench spanner set at 35 ft lbs.

On Powrtouch Twin Axle models (ONLY), 2 grub screws (per side) situated on the top plate are used to provide extra positional security, these should be tightened securely using the 8mm allen key (not provided).

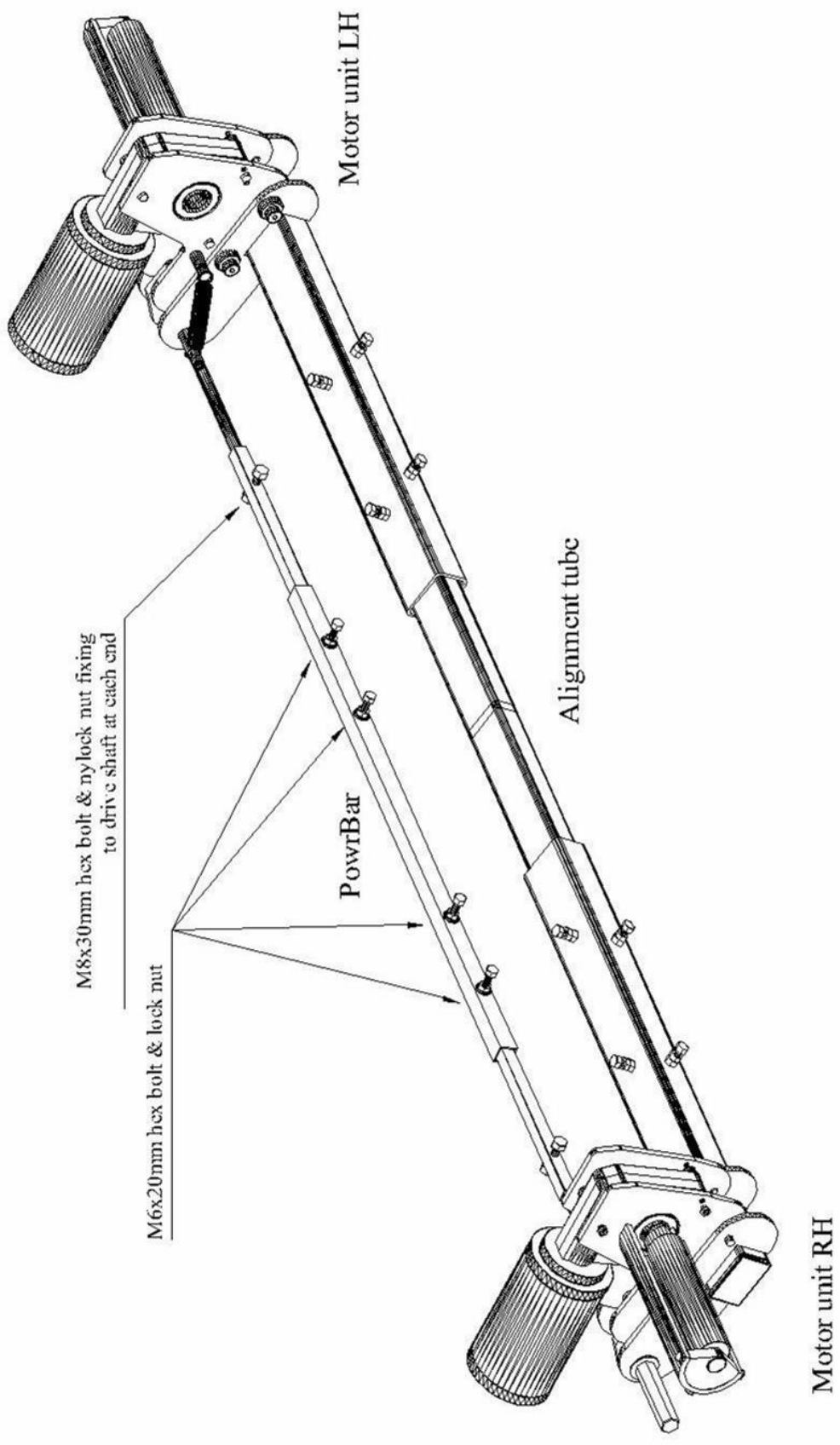

Fig 5. Drawing showing PowrBar Installation

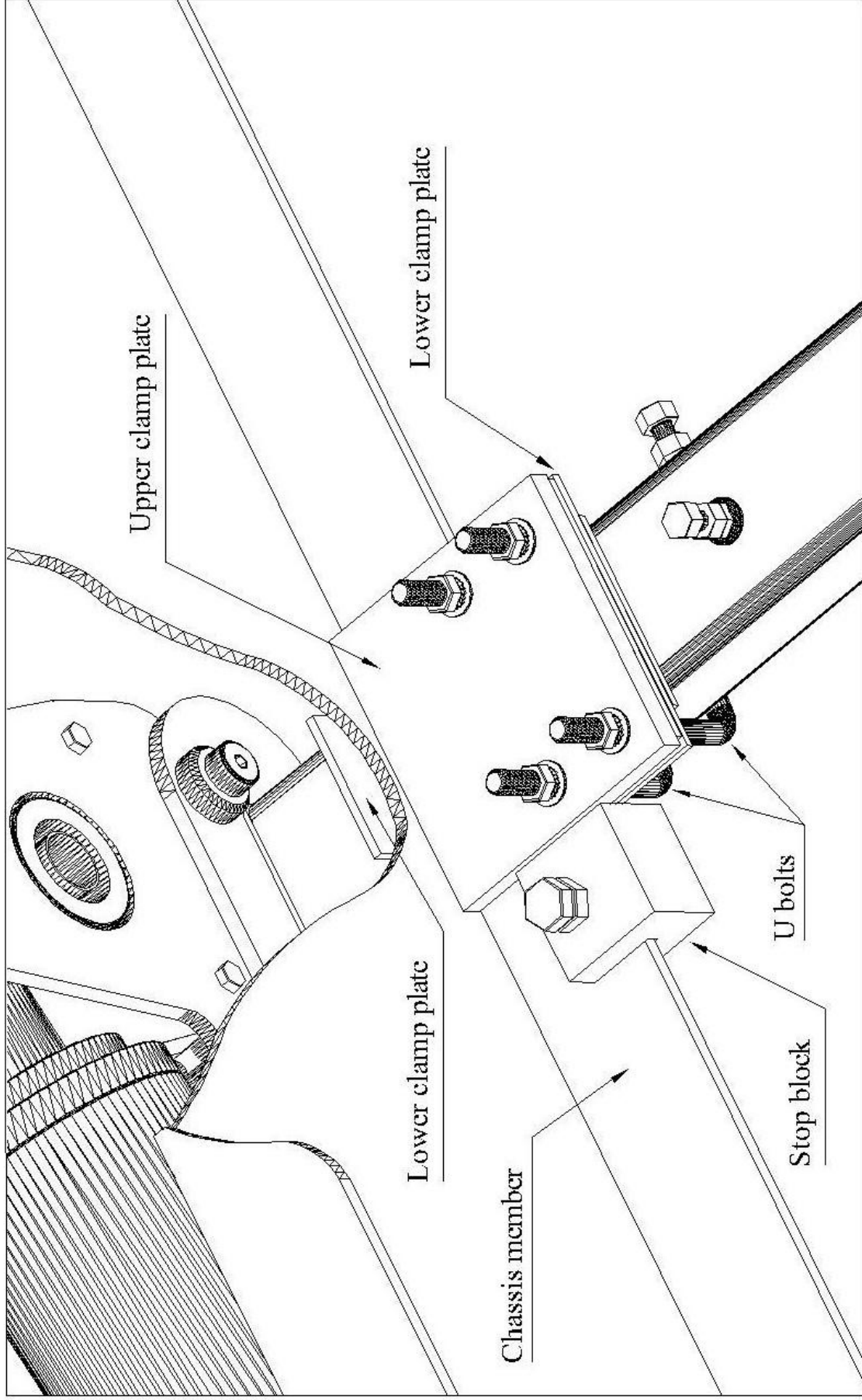

Fig 3. Drawing showing clamping arrangement

2.7. Powrbar Installation (If required)

The Powrbar installation kit is as detailed in Fig2

Fitting of the unit is quite simple but before you begin please check the parts list and familiarise yourself with how your unit fits together. Fig 5 shows how the parts look assembled.

With the drive rollers disengaged then in the approximate installation position under the caravan loosely assemble the Powrbar parts as shown in Fig 5. Choose which side of the trailer to start installation and raise one end of the loosely assembled Powrbar and slide it over the round drive shaft (internal end of hex shaft). Repeat this process on the other side of the caravan/trailer so that the Powrbar is now suspended from the drive shafts. Using the two M8 x 30mm bolts and nyloc nuts secure each of the Powrbar end tubes to the drive shafts. Then ensure that the centre tube is moved into a position approximately central to the whole Powrbar assembly before securing it with the four M6 x 20mm bolts and the locking nuts.

Be sure that the Powrbar or Centre Bar does not foul any other system, such as the brake cables water tanks etc.

2.8. Electrical Assembly

AGAIN - PLEASE ENSURE THAT THE BATTERY AND MAINS LEAD ARE BOTH DISCONNECTED FROM THE CARAVAN BEFORE COMMENCING INSTALLATION

Note: - The terms right hand (UK Nearside) and left hand (UK Offside) referred to on the electronics control box are determined by standing in front of the caravan (at the ball hitch) facing the caravan.

The recommended site for the Electronic Control Box (ECB) is inside the caravan in the dry (bedding) locker behind the battery box. Before choosing a position for the ECB consideration **must** be given to allow access to the jack socket for the emergency/umbilical cable. The electronics box should be screwed to the floor using the screws provided. **Please note some caravans have under floor cables and/or pipes, checks must be made to ensure it is safe to drill.** If safe to do so then drill four 10 mm diameter holes in the floor approximately 150 mm from the control box for the motor wires to be fed into the caravan. Start routing the wires from the motor, remembering to leave a small amount of slack cable near the motors to allow for their movement when the drive rollers are engaged. The motor wires (two each) and Powractor wires (if fitted) can now to be routed along the underside of the caravan floor using the P clips provided (securing of the cables can be made with a suitable staple gun and the correct size staples – not provided). Care should be taken to ensure that the cabling is securely fitted so that no chaffing can occur and that it does not sag. Also ensure cables do not make contact with the steel chassis (unless suitable cable clips are used – not provided). If the Powrtouch is fitted in front of the wheels then the ECB should be wired as shown below.

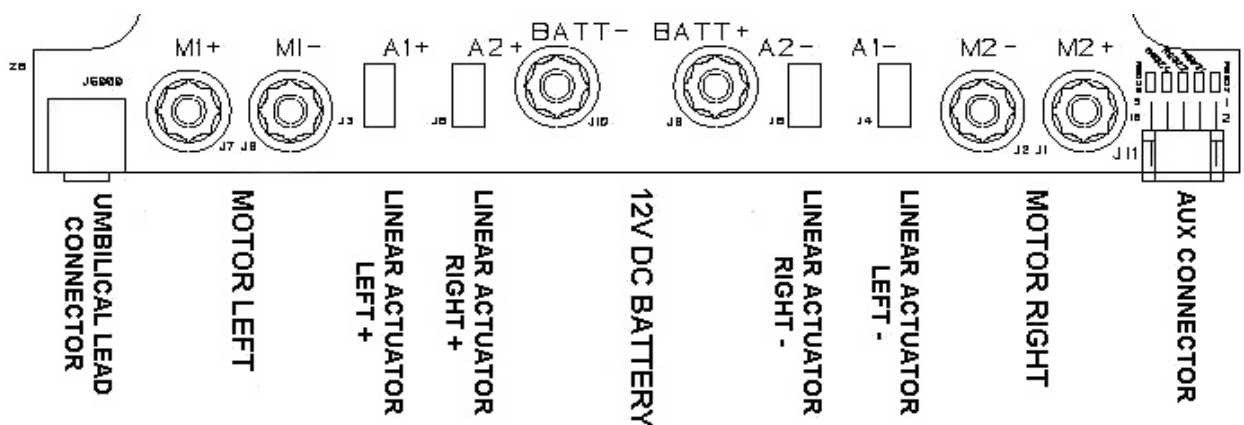

Should the Powrtouch be fitted behind the wheels then the polarity of the motor (only) wires should be reversed from the positions shown in fig 6A1. Powrtouch All Wheel Drive should be wired as shown in Fig 6C1.

The Powractor on two motor fit should be wired as per Fig 6D1. For an All Wheel Drive then they should be wired as Fig 6E1

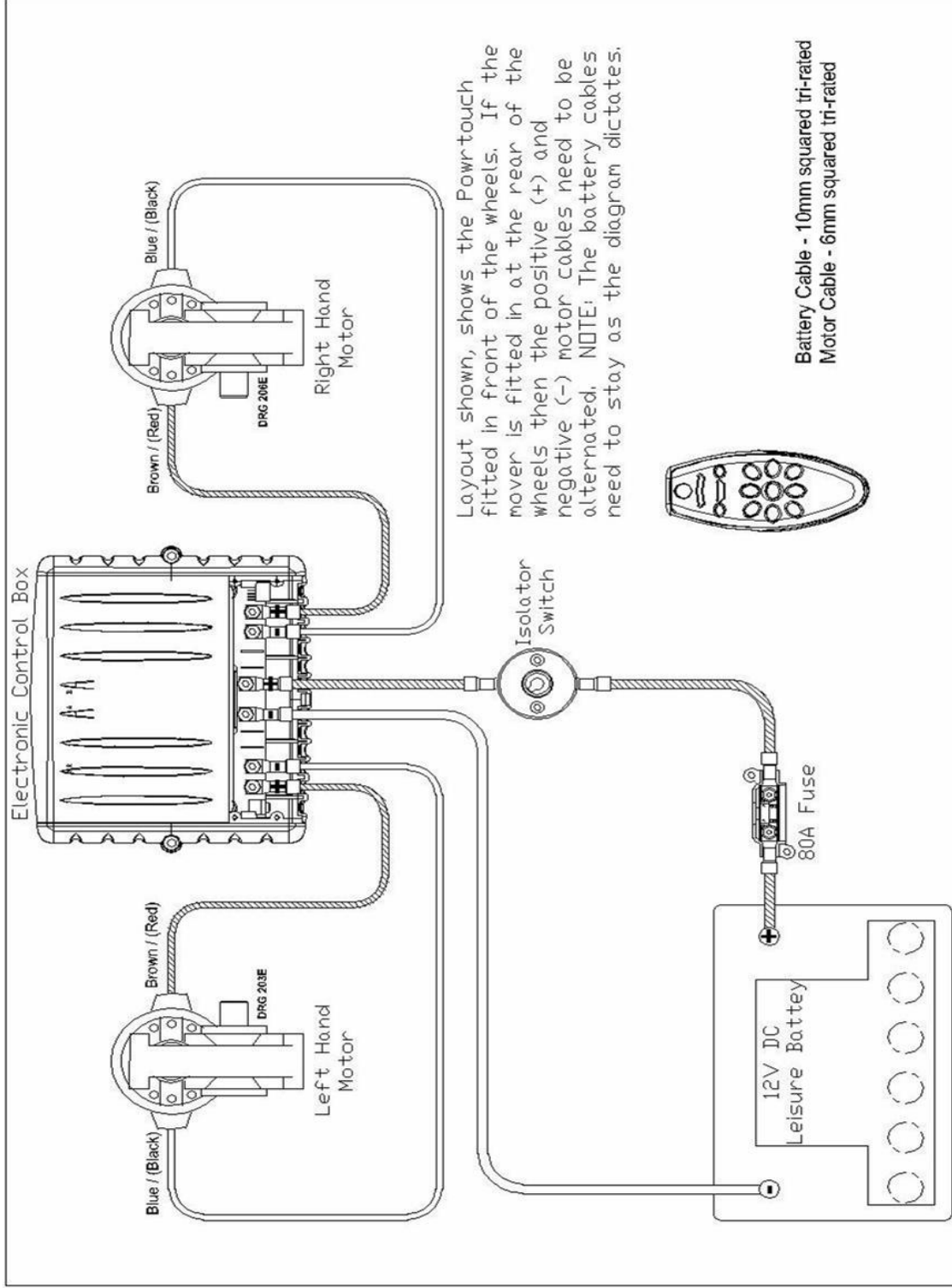

Fig 6A1. Electrical schematic diagram - Powrtouch Fitted Infront of the Wheels

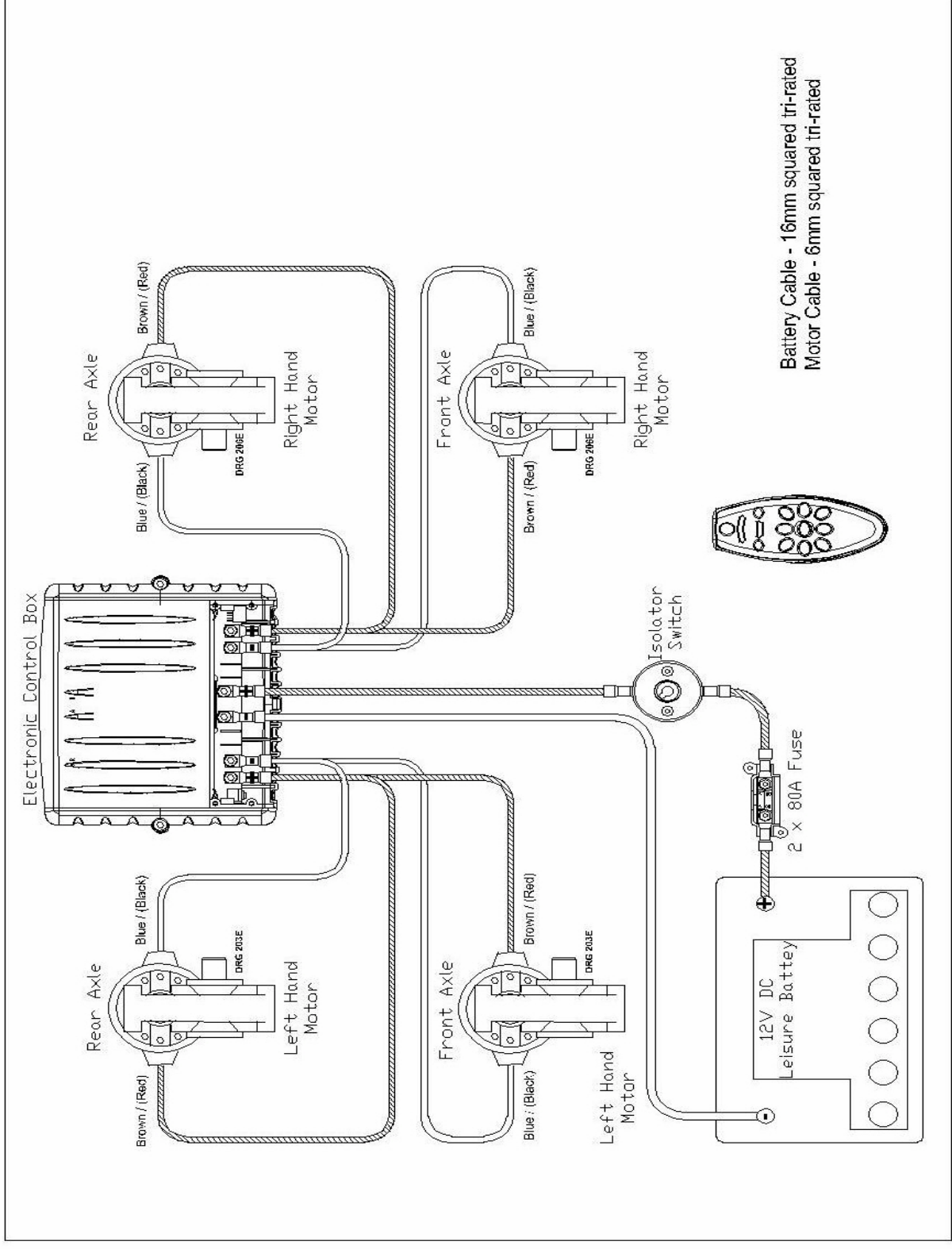

Fig 6C1. Electrical schematic diagram - Powrtouch All Wheel Drive

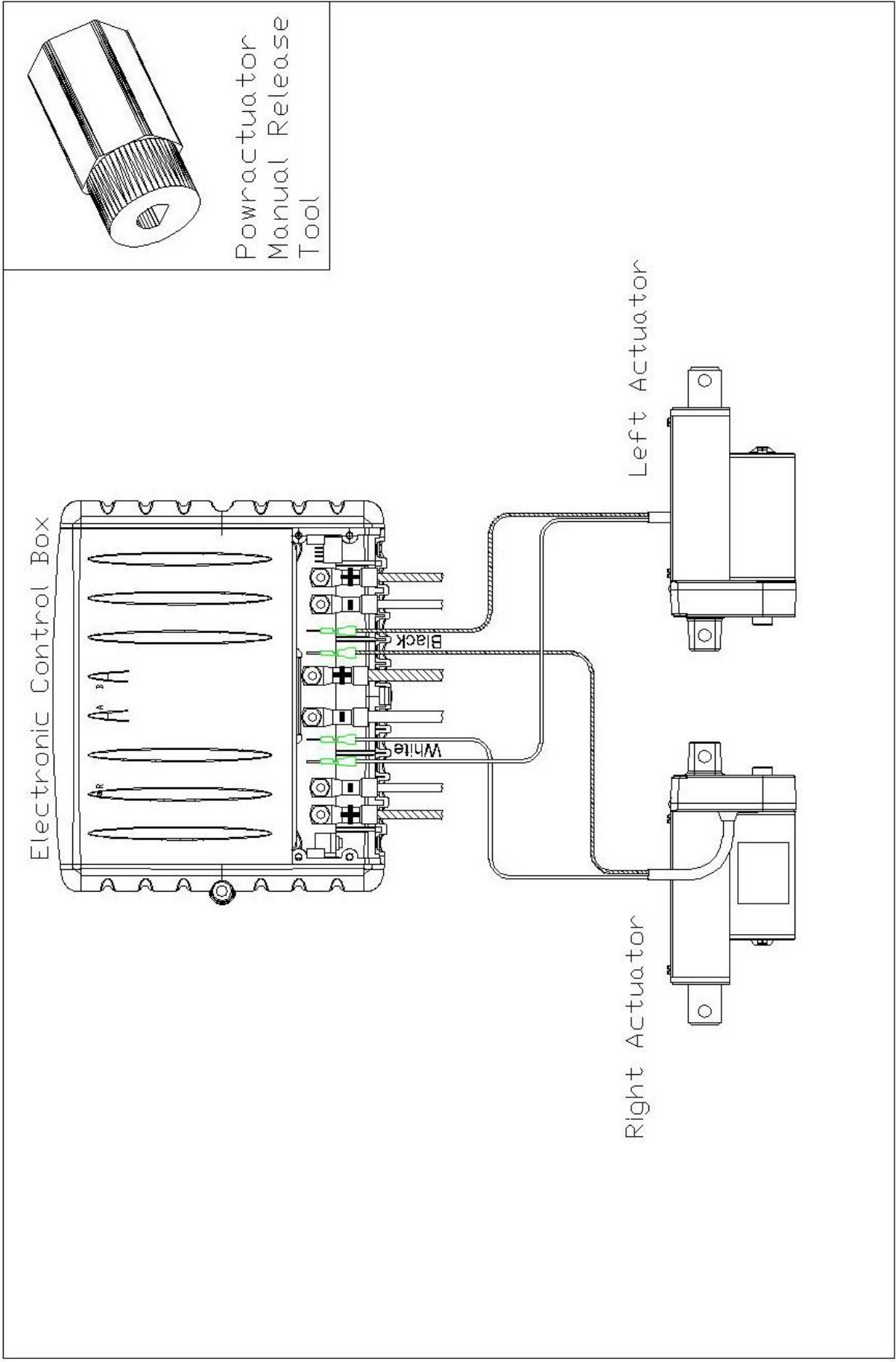

Fig 6D1. Electrical schematic diagram - Powrtouch Linear Actuators

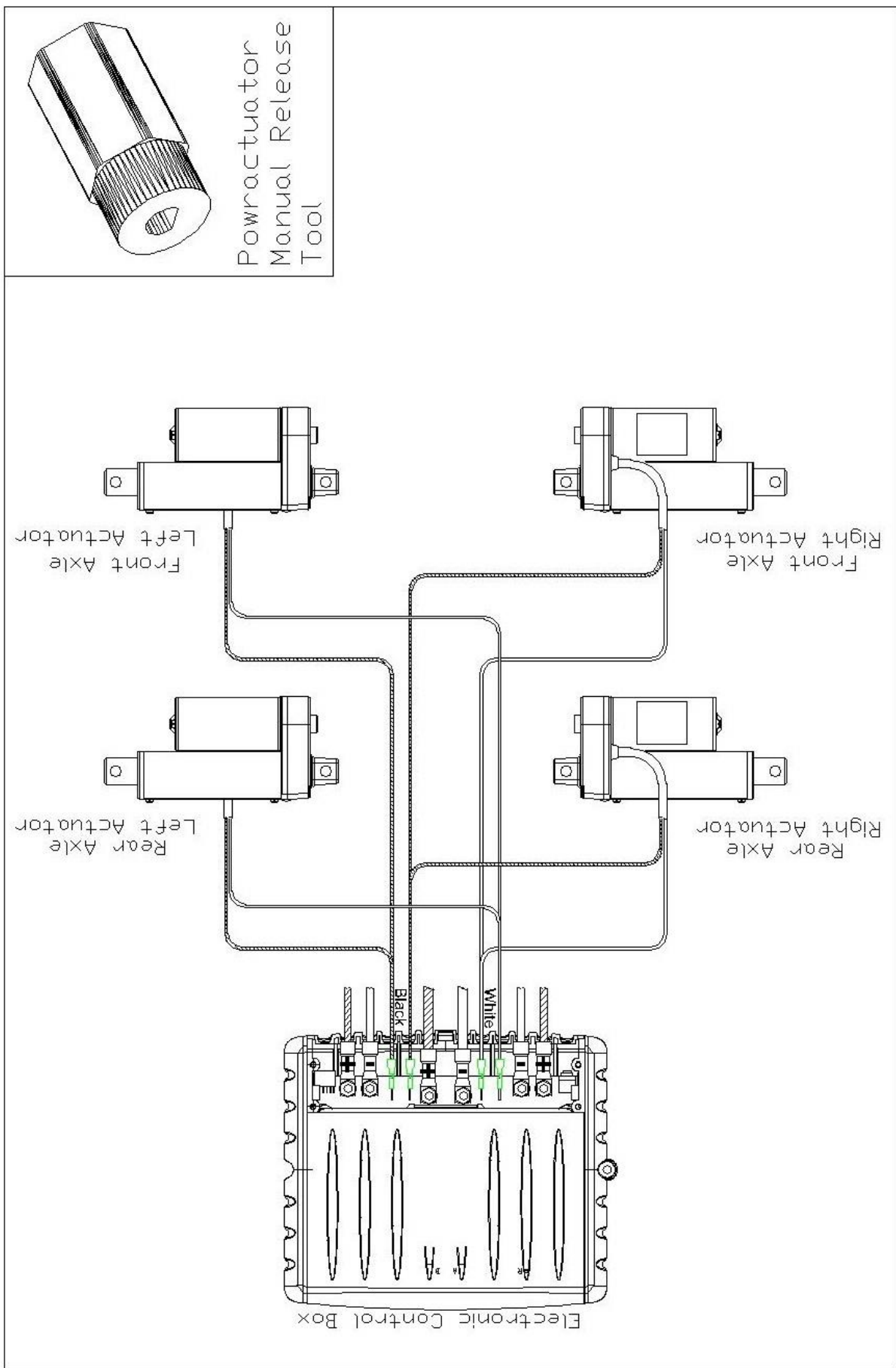

Fig 6E1. Electrical schematic diagram - Powrtouch Linear Actuators AWD

Any excess motor cable should then be coiled up (secure with cable ties as necessary) in a convenient position inside the caravan/trailer. When coiling the motor cables please ensure that the coils are kept as far away from the electronics box and aerial as possible. It is recommended that motor cables should not be cut to ensure they are 1) of equal length and 2) if the Powrtouch is removed and refitted to a new or different caravan the cables can easily be reused.

Please ensure the battery is in good condition (See Section 4 Paragraph 4.4), a fully charged **leisure** battery MUST be used and can be either a lead acid or gel type (**Please note that car batteries are not suitable to operate Powrtouch Movers.**) An 85 –Ampere Hour for single axle and 110-Ampere Hour for twin axle caravans are the recommended battery size for optimum operation. Smaller batteries may be utilised but mover performance may be reduced. The aerial (thin black cable) should be let through the caravan/trailer floor directly next to the electronics box (drill small 3mm hole as required) and then run in a straight line away from the electronics box and all motor cables. The aerial should be clipped in place with the last 25mm (1 ins.) of the cable left dangling down. Under no circumstances should the length of the aerial be changed either by cutting or extending by splicing into it.

2.9. Connecting to the Battery

Please be aware of the need for access to the isolation switch when parking your caravan/trailer. The switch should also be fitted to be in an accessible position whilst the unit is in operation.

The Powrtouch is supplied with an inline switch which allows the isolation of the electrical control box from the Battery. The suggested location for the fitting of this switch is within the battery box, but it MUST be placed in the sealed side compartment (see below) usually beneath the 240v mains connector. The reason for this location is to ensure that the Powrtouch isolation key will obstruct the use of the 240 volt ac mains connector; under no circumstances should the Powrtouch be operated while the caravan is connected to the 240 volt ac supply. Drill a 25mm hole with the saw and the two 5mm clearance holes for the fixing nuts and bolts, when the holes are drilled install the switch and tighten up the nuts and bolts.

The electronics box and the in line fuse MUST NOT be located in the battery box or any compartments containing gas bottles. This is due to risk of explosion caused by leaking gas and a spark generated by the electronics, isolation switch or fuse.

The 10mm battery cables are provided correctly terminated for their application and the length of these cables must not be altered in any way. The 1500mm Black or Blue negative battery cable is connected directly from the negative terminal of the caravan battery to the negative terminal of the Electronics Control Box. n.b. Starting from the non terminated (bare end) 1000mm of this cable is double insulated and this part of the cable must be connected to the battery. The 1000mm Red or Brown positive battery cable that is all double insulated is used to connect the positive terminal of the battery (bare end) to one terminal of the inline fuse positioned in the caravan. These battery cables have to pass through drilled holes in the battery box to gain access to the caravan these the cables should be protected from chaffing and the battery box be sealed from leaking gas by the special grommets (supplied) these grommets MUST be fitted. The 250mm Red or Brown positive battery cable is connected to the other terminal of the inline fuse that there is to protect the ECB from overload or misuse and the other end is then connected to a terminal of the isolation switch. The 1200mm Red or Brown Cable then connects the second terminal of the isolation switch to the positive connection on the Electronics Control Box. Once connected these cables will then need to be securely fitted using the 'P' clips provided.

When making the connections of the battery cables ensure that their polarities are correct (Red or Brown Cables to Positive and Black or Blue Cables to Negative) should they be connected incorrectly then this will result in damage to the electronics box.

All cables can then be connected to the electronic control box ensuring that they are fitted in accordance with the labels on the control box. The electrical assembly is now complete and any hole(s) drilled for motor wires to access the caravan should now be sealed with the silicon sealant to prevent ingress of damp or water.

Please note that the above wiring instructions are for fitting all Powrtouch Single Axle and Standard Twin Axle to the relevant caravans. If fitting an All Wheel Drive Powrtouch then the battery cables will be 16mm diameter, will be of the same configuration but will be longer.

**If you are unsure about the installation consult a Qualified Powrtouch Engineer,
Telephone: 01425 289293 – Take Option 2**

SECTION 3 – LOOKING AFTER YOUR POWRTOUCH

3.1. Cleaning the Powrtouch

It is recommended that after your Powrtouch has been fitted it would benefit from being sprayed with a light coating of wax oil (this could be repeated on an annual basis) by doing this you will be giving the mover better protection from water and rust and potentially prolonging its life well beyond its full 5 year guarantee. If necessary it can be washed with clean water but under no circumstance should a pressure washer be used on a Powrtouch system.

3.2. Cleaning the Rollers

Ensure that the rollers are kept clean; this can be undertaken by washing with a hard brush. **For safety reason it is recommended that isolation switch is turned off and the key removed prior to cleaning the rollers**

Also check that no stones or other debris are trapped in any part of the mechanism.

3.3. Greasing the Powrtouch

It is essential that the unit is re-greased periodically, or at a minimum every six months, clean and remove old grease (using a WD40 or similar cleaning solution) and then re-grease all moving parts. i.e. Locking cam system and the sliding motor mounting plates as shown below. Any silicone based grease will be suitable but Powrwheel Limited firmly recommends the use of a spray on motorcycle chain grease available suitable stores.

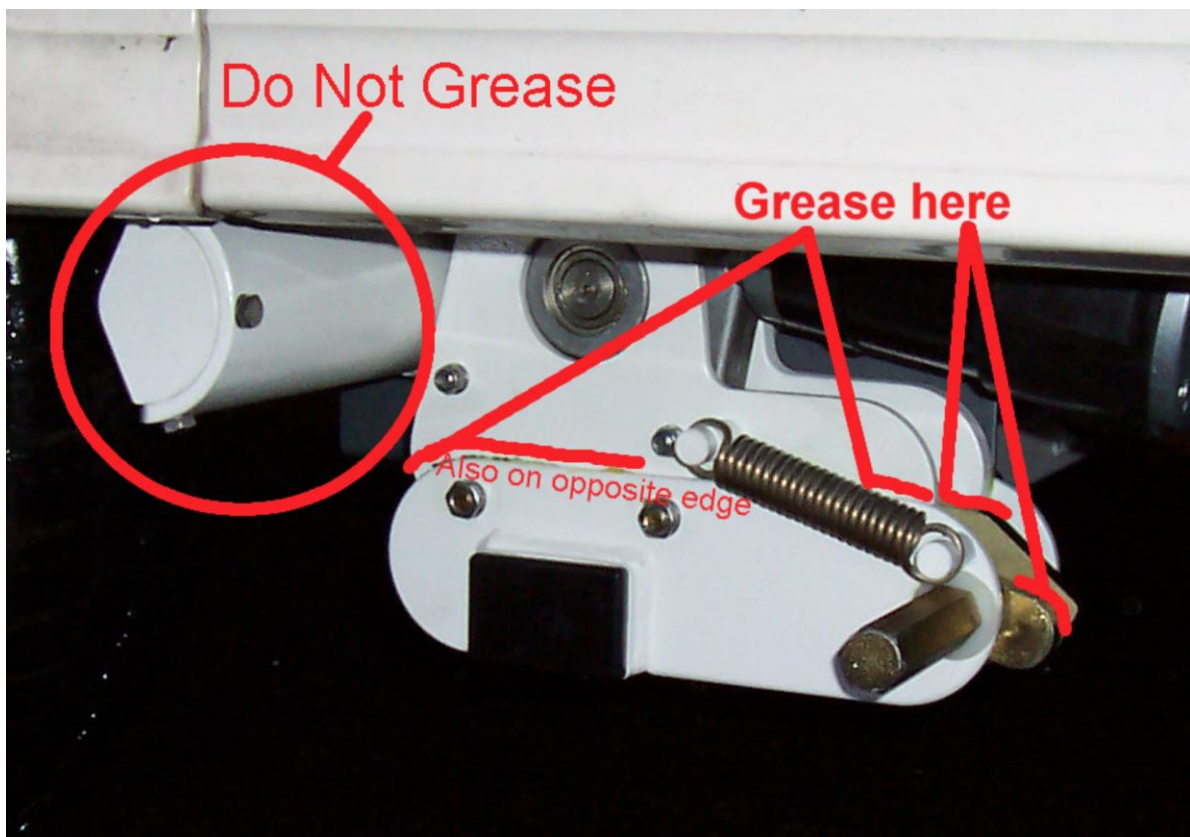

SECTION 4 – GUARANTEE & FAULT FINDING

4.1. Guarantee

A NEW Powrtouch is covered by a FIVE YEAR no quibble parts and labour guarantee and a RECONDITIONED Powrtouch for THREE YEARS.

N.B. IT IS AT THE COMPANY’S DISCRETION WHETHER THIS GUARANTEE IS TRANSFERABLE TO A NEW OWNER, AND A CHARGE WILL BE MADE FOR ANY AGREED TRANSFER.

PLEASE CONTACT POWRWHEEL LIMITED SALES TEAM FOR FURTHER INFORMATION.

Please note that our guarantee covers reasonable use of the mover, it does NOT cover damage caused by misuse. The guarantee cannot cover any malfunction caused by the fitting of the mover if the fitting has been done on a DIY basis or purchased from and fitted by a dealer or agent.

Any unauthorised modifications, use of non original Powrtouch spare parts or failure to respect the installation or operating instructions will render this guarantee null and void.

To ensure the validity of the guarantee please carry out maintenance in accordance with Paragraph 3.3 i.e. clean and grease.

Powrwheel Limited reserve the right to make a call out and/or repair charge for any work required to be undertaken to rectify faults that are outside of the company’s control. i.e. **caravan battery failure**, incorrect or poor fitting, misuse, accidental damage, etc.

4.2. Reporting a Fault

ALWAYS ENSURE THAT YOUR BATTERY IS FULLY CHARGED AND IF YOU ARE IN DOUBT ABOUT BATTERY STATUS USING THE BATTERY GAUGE ON YOUR CARAVAN CHECK WITH THE VOLTAGE CHART PARAGRAPH 4.5 – BELOW

PLEASE PAY SPECIAL ATTENTION TO TESTING THE BATTERY UNDER LOAD.

TO CARRY OUT THESE CHECKS THE CARAVAN MUST BE DISCONNECTED FROM ITS 240 VOLT SUPPLY.

Before you call Powrwheel Limited to report a fault you should have the serial number of your Powrtouch available as you will be asked for this information, it allows a Powrtouch Engineer to locate the full manufacturing status of the mover and be able to advise you accordingly. Also before reporting a fault you are requested to check through the fault finding list below to see if any of them can solve the problem, failure to comply to this may result in you be asked to carry out some of these tests thus delaying action to repair if required

4.3. Electronics Control Box - LED Status

LED Status Array in use	Red Light	Green Light	
Power Up Normal	OFF	ON	
Incoming Data Transmission	ON	OFF	
Awaiting Configuration	FLASH	FLASH	Alternating
LED Status Array - Fault Diagnosis			
PCB Over heat	FLASH		
Low Caravan Battery Voltage		FLASH	
Over current on MOSFET Drive	FLASH	FLASH	Together

4.4. Fault finding Chart

Symptom of Fault	Possible fault and method of correction
Unit fails to operate – seems completely dead	Reset the electronics control box by turning off and removing the isolation key for at least 20 seconds and then turning on again. The green light on the electronics box should be illuminated.
Unit fails to operate – seems completely dead – Red Light flashing on ECB	Over heating remove isolation key and leave 5 minutes to see if the thermal Fuse will reset itself, RED LIGHT WILL STOP FLASHING and the Electronics Control Box it should not be feel hot.
Unit fails to operate – seems completely dead	Check the in line fuse is not broken and 12 volts dc is getting to the ECB
Unit fails to operate or operates intermittently	Check the battery voltage of the handset is correct at 9.5 volts. If the 6 red LED's flash twice when the handset is turned on this is also an indication that the handset battery voltage is low This also can be checked by use of the emergency umbilical cable.
Unit fails to operate or moves intermittently	Radio interference, check by using emergency umbilical cable
Unit fails to operate or moves intermittently	Badly connected or corroded battery terminals, check battery terminals, clean and connected as required.
Unit fails to operate or moves intermittently – Green light flashing on ECB	Caravan battery low - check voltage of battery (see battery voltages chart paragraph 4.4 above), charge or renew caravan battery.
Caravan fails to move or moves intermittently	Caravan battery low - with the rollers engaged move the caravan and check the voltage drop on the caravan battery meter, if this drops below 12 volts, it is advisable to have the battery tested by an accredited supplier, then as necessary charge or renew caravan battery.
Roller will not disengage or engage (Manual Operation), Hex Shaft rotates fully.	Call Powrtouch Technical Department
Roller will not disengage electrical operation (Powractuation fitted)	See Section 1 Paragraph 1.11 Removing the Rollers.
Rollers slip on wheels	Disengage rollers and check gap to tyres 15mm for large roller versions and 20mm for small roller versions; check tyre are not badly worn pressures
IF IN DOUBT CONSULT A POWRWHEEL ENGINEER. TEL: 01425 283293.	

4.5. Checking the charge state of a 12 volt battery

APPROX CHARGE STATE	VOLTMETER READING (No Load)	HYDROMETER READING
100%	12.7 v or over	1.27
75%	12.5 v	1.23
50%	12.4 v	1.20
25%	12.2 v	1.17
Discharged	12.0 v	1.10

Please Note: Voltage readings should be taken at least 4 hours (and could be up to 12 hours depending upon charging rates) after recharging to obtain an accurate reading

The above figures are for the battery when under no load, if a battery is on the point of failing or not fully charged then the only test that will determine this is to take the readings under load (drop test). This can be achieved by using the Powrtouch mover with the rollers engaged to the tyres and driving both rollers forwards or backwards, if the reading drops to 12 volts or less the safety cut out on the ECB will stop the Powrtouch to prevent damage to the battery. However this is an indication of insufficient battery voltage to drive the Powrtouch caused by an under charged or failing battery. PLEASE BEAR SAFETY IN MIND AND THAT BEING IN THE CARAVAN WATCHING THE METER YOU DO NOT DAMAGE THE CARAVAN BY RUNNING INTO AN OBSTRUCTION

The above voltages are accurate at 25 degrees centigrade, in temperatures less than this the battery performance and output decreases by 1.25% per degree